



**CAR BENCH**<sup>®</sup>  
CAR BENCH INTERNATIONAL SPA

*ONLY THE BEST CAN BE NUMBER ONE*

# **ELECTRO KRAFTANTRIEB CB-EPO1**





## MINI DOZER FÜR ELEKTROLEISTUNG

Zug- und Drucksystem für schnelle Reparaturen, batteriebetrieben bis zu einer Kapazität von 5 Tonnen.

Es kann auf engstem Raum verwendet werden weil da es keinen elektrischen Draht oder Hydraulikschlauch gibt

**STANDARD KIT:**  
**620 X 420 X 150mm**  
**Gewicht: 18Kg**



## MECHANISCHER VERBREITER FÜR ELEKTROLEISTUNG



## SMART ZUGWERKZEUG FÜR ELEKTROLEISTUNG



## ZUBEHÖRSÄTZE

620 X 420 X 150mm  
Gewicht: 20Kg

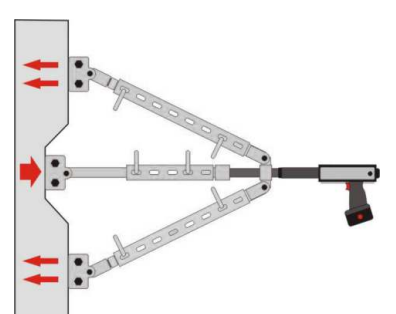
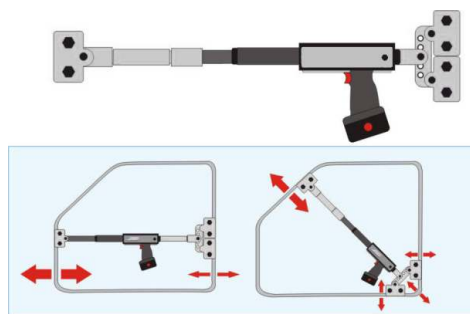
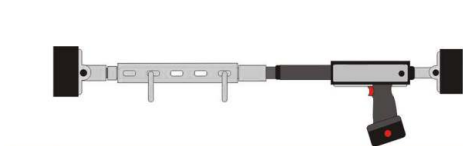
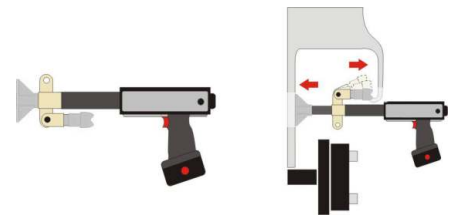
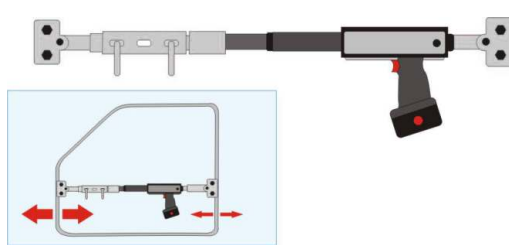
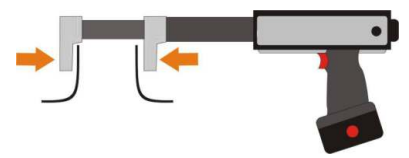
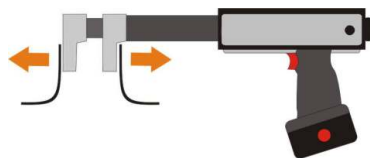

# ELECTRO KRAFTANTRIEB CB-EP01



## TECHNISCHEN MERKMALE

Zugkraft:	5 ton
Druckkraft:	5 ton
Kolbenhöhe:	130 mm

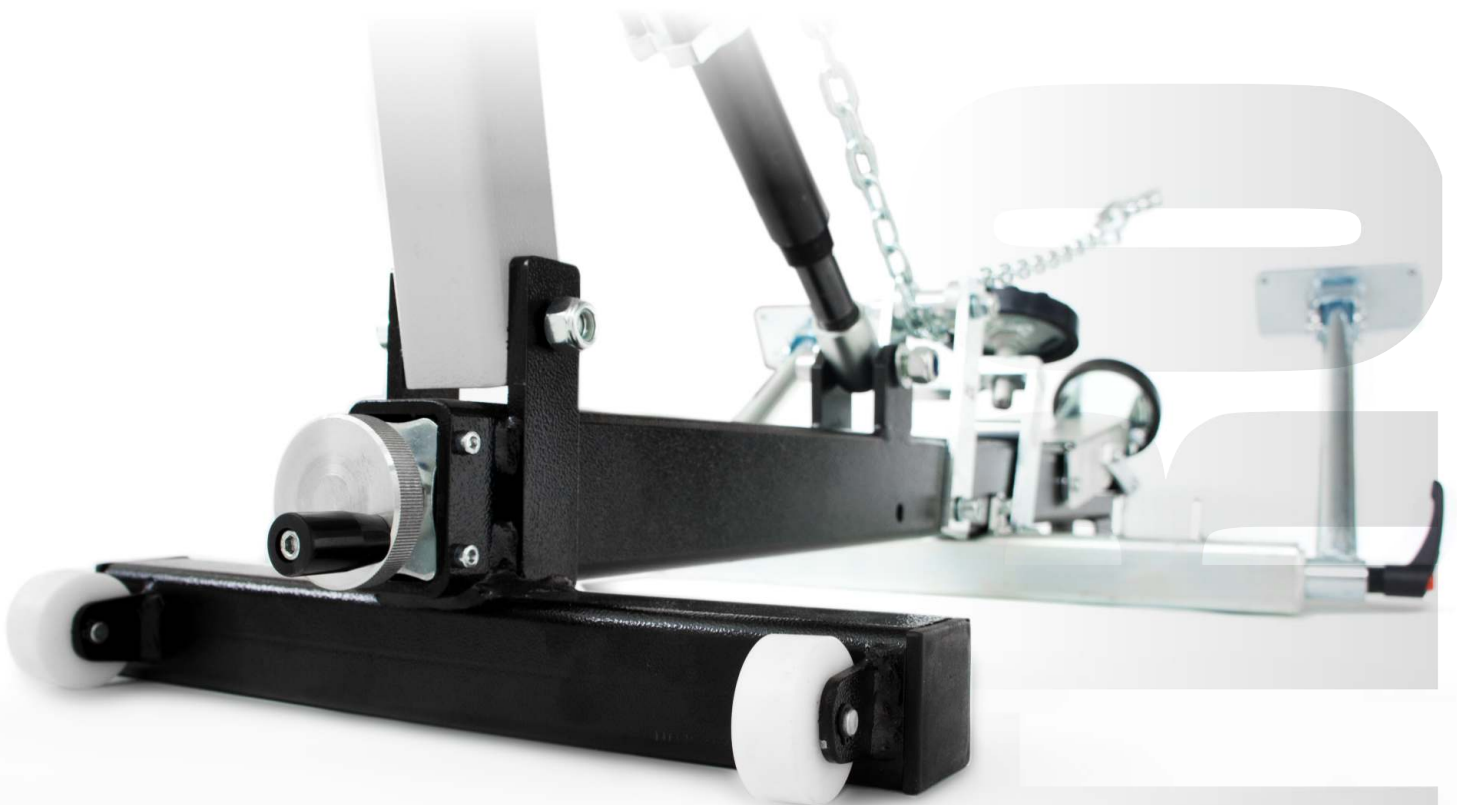

**CAR BENCH  
TRAINING ACADEMY**

REPARATURMETHODEN

CAR BENCH  
AUSRÜSTUNG  
SCHULUNG

AUTOHERSTELLER  
MAßGESCHNEIDERTE  
SCHULUNGEN



**Car Bench International S.p.A.**  
Via Dorsale, 22 - 54100 Massa (MS) - ITALY  
info@carbench.it - ph. +39 0585 251261  
www.carbenchinternational.com